



700 Series

code 00004
code 00007
code 10607
code 00006
code 00600

00004 700 DIST
 SELF SUPPORTING
 FAST FIT

GENERAL MECHANICAL FEATURES

Structure	Epoxy fiberglass
Finishing	Polihurethane Paint
Colour	White RAL 9000 (Standard) Grey RAL 7001 (Option)
Irradiation Elements material	Brass
Ferrule	Chrome plated Brass
Chromium plating	20m copper, 20m nickel, 5m chrome
Working temperature	-35C +80C
Max Wind resistance	150 Km/h

ENVIRONMENTAL SPECIFICATION

Temperature, salt, ice, sun irradiation resistance in accordance with MIL-STD 810E

Vibration resistance in accordance with MIL-STD 167-1

Shock resistance in accordance with MIL-STD 810E

Treatments and paintings in accordance with MIL-T-704K

ELECTRICAL FEATURES

Frequency	1,6 - 30 MHz TRANSMISSION ATU 0,15 - 30 MHz RECEPTION with transformer
Polarization	Vertical
Horizontal Irradiation	360°
Vertical Irradiation	60°
Connection	TX with high insulation cble RX with Coax cable RG-58 or RG-213
Connector	8 mm Bolt

HF-SSB BLU

HF-SSB BLU



CODE	00004	00007	10607	00006	00600
Model	700 DIST	700 AUTO	700 P	700 ML	700 ML 3P
Fiberglass lenght	7,0 mt	7,0 mt	7,0 mt	7,0 mt	7,0 mt
Electrical Lenght	6,7 mt	6,7 mt	7,0 mt	6,7 mt	6,7 mt
Max Power	800 W	800 W	800 W	800 W	800 W
Wheight	9,8 Kg	3,4 Kg	3,4 Kg	2,6 Kg	3,5 Kg
Sections	2	2	2	2	3
Bottom Diameter	39 mm	39 mm	39 mm	39 mm	40 mm
Lenght bottom el.	4,0 mt	4,0 mt	4,0 mt	4,0 mt	2,3 mt
Lenght medium element					2,3 mt
Lenght top element	3,0 mt	3,0 mt	3,0 mt	3,0 mt	2,3 mt
Base torsione force	150 N	150 N	150 N	50/90 N (1)	45/85 N (1)
Package Size cm	398 x 21 x 21	390 x 21x 21	407 x 21 x 21	400 x 21 x 21	300 x 21 x 21

(1) depend from bracket distance

10122 RX - T - 40 WATERPROOF BOX TRANSFORMER CONNECTION

Frequency	0,15 - 30 MHz RECEPTION
Connexion	Coaxial cable
Ground	Side Bolt
Lightning Protection	Gas arrester



FLANGE CODE 00004 FIXING MASK

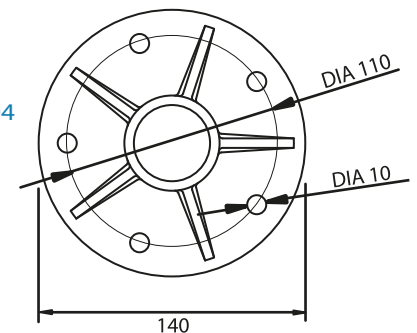

info@banten.com

www.banten.it