



PW3-BC chromed whistle 20/75 m, Ø300 mm + electric valve

Quick Overview

Approved whistle complete with chromed or white horn Ø300 mm. Electric valve and mounting accessories, for compressed air operation 6/12 bar. Meets COLREG 1972 IMO class III regulations. Approvals: RINA, LLOYD'S REGISTER MCA, BUREAU VERITAS, BSH and NMMA.

Part n.	Name	Voltage (V)	Consumption (A)	Hz	dB (1/3 oct) (1m)	Hose (ID) (mm)	Dimensions (mm)
15200212	PW3-BC	12	4,5	315	132	8 / 6	Ø300x449x260
15200213	PW3-BC	24	2,5	315	132	8 / 6	Ø300x449x260

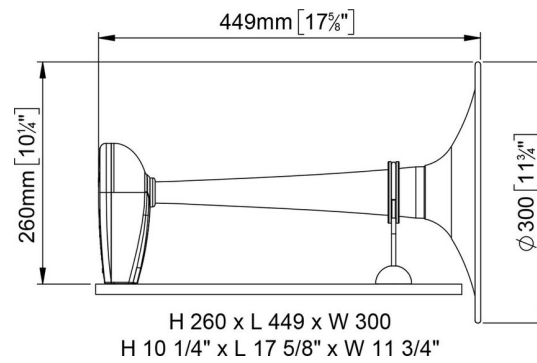

RT6/4 Nylon tubing $\varnothing 6/4$ or $\varnothing 8/6$

M3 Compressor AISI 304 8 l