



VR/ VRC/VFF 600 VERTICAL WINDLASS



THIS PAGE INTENTIONALLY LEFT BLANK

Contents

Introduction	page 4
Important Information Safe Operation	
Installation	page 5
Installation Instructions	
Depth of the Chain Locker	page 6
Handy Hints	page 7
Electrical Information	page 7
Circuit breaker	
Deck switches	
Isolating switch	
Batteries	
Rotation	
Wiring layout	page 8
VR600 & VRC600	page 9
Operating Instructions and Servicing	
Maintenance and Assembly Instructions	page 10
VFF600	page 11
Operating Instructions and Servicing	
Maintenance and Assembly Instructions	page 12
Rope and Chain	page 14
Rope Chain Management System (RCMS) Adjustment	
Line Care	
Rope/Chain Splice	
Troubleshooting	page 15
Water Protection Diagram	page 15
Warranty and Warranty Registration Card	page 17
Drawings	
Deck Template	
Exploded View of VR600 Atlantic	
Exploded View of VR600 Atlantic with lock pawl	
Exploded View of VRC600 Atlantic	
Exploded View of VFF600 Freefall	
Wiring Diagram	

INTRODUCTION

Thank you for purchasing a Muir Atlantic Windlass. Muir go to great lengths to develop anchoring systems that not only meet all of your performance and safety requirements, while also being designed with a style and finish that enhances the aesthetics of your vessel. With Muir's commitment to quality and use of superior materials and processes we know you will be pleased with your investment. Rest assured that through correct installation, operation and maintenance, your new Muir Windlass will give you years of reliable performance.

IMPORTANT INFORMATION

To avoid damage to the geardrive, windlass or vessel when bringing the anchor up hard, it is a preferred practice to mark the chain at approximately 5-meter intervals from the anchor, to alert the operator to the anchor position. Alternatively an Auto Anchor can be used.

Under no circumstances should the windlass be operated if it is stalled or overloaded.

If anchor retrieval is impaired by high wind, heavy seas or if the anchor is snagged, ease the load by either motoring or sailing slowly forward into the wind with a chain stopping device in place. The rope or chain should be cleated off and the anchor driven out by the engine, otherwise the gearbox or shaft can be damaged.

SAFE OPERATION

- Ensure that hands, feet, hair and clothing are kept clear of the windlass and other loose gear when in operation.
- Ensure no one is swimming nearby as anchor is lowered or retrieved.
- Keep hands well clear of capstan, gypsy, chain and rope.
- The windlass should never be used for lifting people aloft.
- Do not use a windlass as a bollard for mooring, towing or being towed.
- When the windlass is in use or the anchor stowed, always ensure the clutch is tightened with the clutch handle, and a Chainlock, Devil's Claw or Snubber Line is fitted to retain the anchor. The use of these accessories will prevent excessive loads on the geardrive or accidental release of the anchor.

An optional feature on the VR600 is the gypsy locking pawl, which is used to lock the gypsy, by sliding the locking pawl (located on the top of the chain cover) into the gypsy slots (located in the top flange of the gypsy). This will prevent the release of chain when at anchor or when the anchor is stowed.

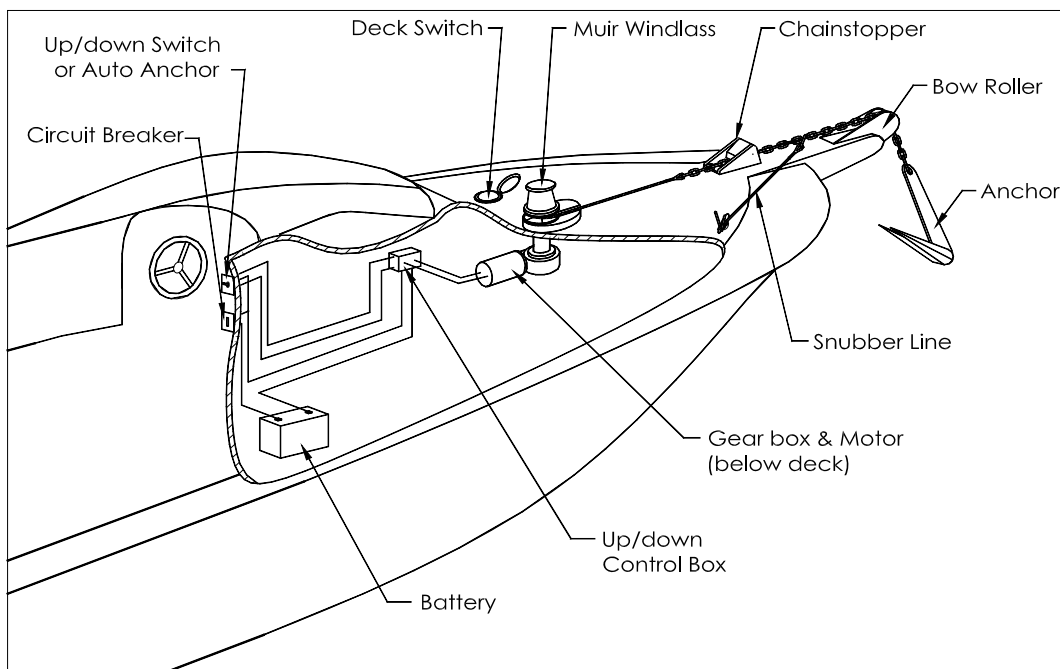

INSTALLATION INSTRUCTIONS

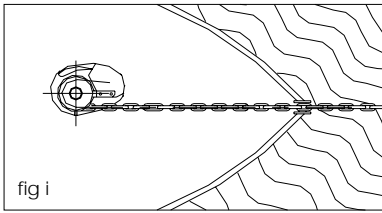

Figure (i)

Locate the windlass centrally fore and aft. Check that the chain leads unhindered to the anchor roller. The chain runs onto the starboard side of the gypsy, wraps around 180° and falls below deck through the chain pipe. Ensure there is sufficient room around the windlass to allow full rotation of the manual clutch handle (if supplied).

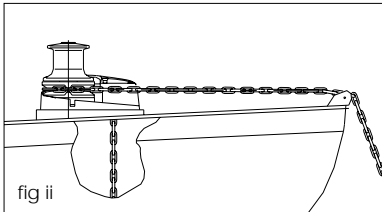

Figure (ii)

The centre height of the gypsy must be in the same plane as the chain lead from the bow roller. If the deck is angled (fore & aft) or curved (port to starboard) a suitably shaped mounting block will be required to spread the load evenly over the deck surface and to mount the windlass base on a level and even footing.

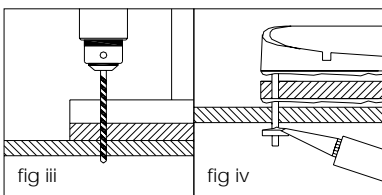
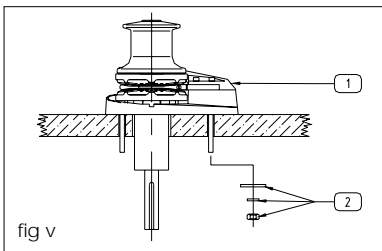

Figure (iii)

Place the shaped mounting block (if required) onto the deck. Using the layout template supplied, mark the mounting centres and cut/drill the holes.

Figure (iv)

Apply an appropriate sealant to the base plate and mounting block (if required) and carefully tighten the nuts and washers onto the threaded studs under the deck. Remove excess sealant.



For aluminium or steel hulled vessels, it is important to insulate the windlass with a non-conductive gasket to avoid corrosion. This also applies below deck for the mounting bolts, nuts and washers.

Where the deck construction is light or of foam sandwich construction, a plywood stiffener of at least 16mm (5/8") thick should be fitted to the underside of the deck to spread the load and to prevent the bolts from pulling through the deck. Large diameter washers on the underside of the stiffener assists to spread the load.

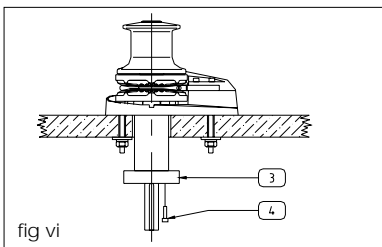

Figure (v)

1. Mount the windlass from above as shown.
2. From below, place washers and nut onto each stud and tighten.

Figure (vi)

3. Locate adaptor and align holes.
4. Fasten using cap screws provided.

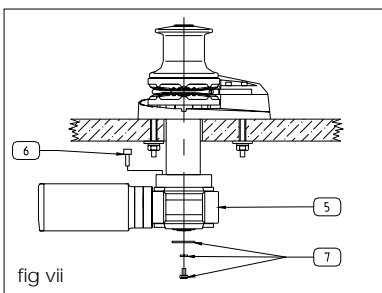

Figure (vii)

5. Grease shaft and key, slide geardrive onto shaft, ensuring key is aligned. Rotate gearbox to preferred mounting position and secure with bolts provided.
6. Locate gearbox and bolt through adaptor.
7. Place washers and bolt in the end of the shaft and tighten.

NOTE: During assembly, grease all moving parts and the deck plate grease nipple with a Lithium/Teflon based grease. The motor/gear drive assembly should be protected with anti-corrosion film or grease tape.

DEPTH OF THE CHAIN LOCKER

Ensuring that the vertical distance, (minimum fall), between the underside of the deck and the top of the completely stored and heaped anchor rode in the locker will assist in determining the installation to suit your vessel. Refer to the fall depth diagrams and the options detailed below. It is also recommended that the chain be directed to the center of the chain locker. (See also water protection diagram on page 15.)

If your vessel does not meet the minimum fall requirements for a vertical windlass, contact your Muir retailer.

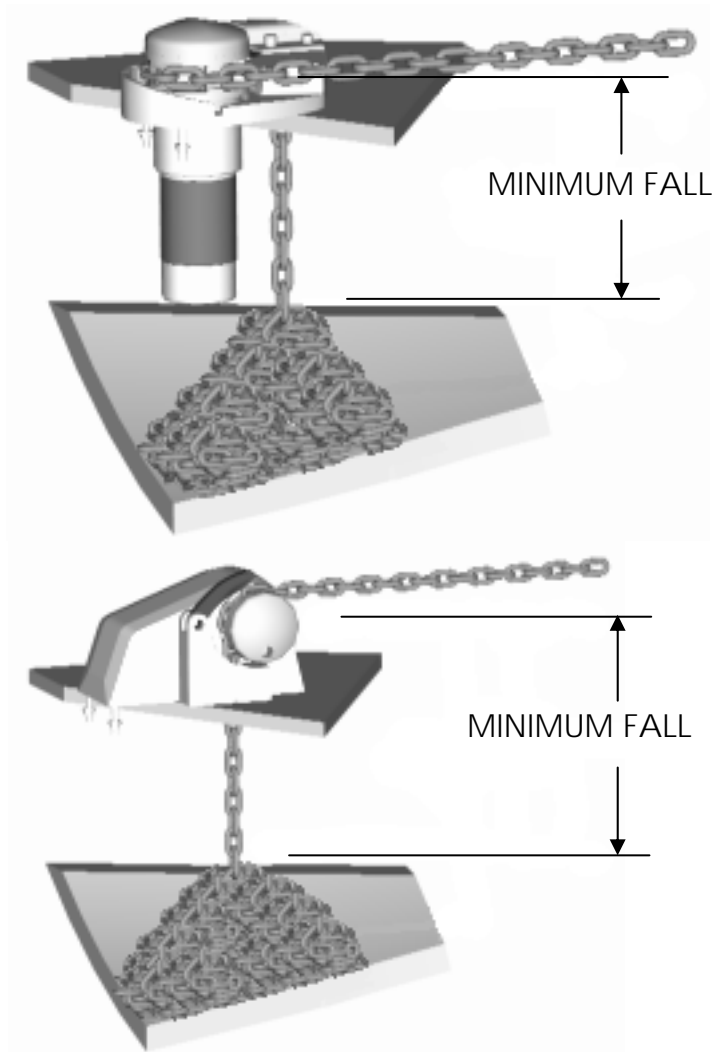

Vertical Windlass: The running gear, gypsy and capstan are positioned above the deck with the motor and gear drive below. Vertical windlasses operate at best with greater anchor rode fall than the horizontal windlass and a minimum fall of 300mm from top of stacked anchor rode is recommended. This is particularly important if using nylon line, which does not fold and stack as well as chain. Vertical windlasses minimise deck intrusion and the modern curved lines of the Muir windlass enhance the look of any vessel. A vertical windlass provides the advantages of a 180-degree wrap of the anchor rode around the gypsy.

Horizontal Windlass: Fully enclosed, above deck, this style is usually preferred where locker space is limited or additional fall is required. The motor and gear drive is fully enclosed in the housing with nothing protruding below deck. The horizontal windlass operates with optimum anchor rode fall of at least 300mm from the top of the stacked anchor rode, and due to the horizontal orientation of the gypsy higher above the deck there is additional fall provided. These units are ideally suited for vessels with less locker space.

Vertical Windlass Model	Horizontal Windlass Model	Minimum Fall (Dist. Top of Pile)
VR/VRC/VFF 600	HR600 - 700	300 mm
VR/C 850 – 1250 & 2200	HR1200	450 mm
VR/C 2500 – 3500	HR2500 - 3500	650 mm
VR/C 4000	HR4000 - 4200	800 mm

HANDY HINTS

It is a common error to locate the windlass too far forward, or too close to the bulkhead, where there is insufficient room for chain and anchor stowage. The chain fall should be positioned in the centre of the chain locker to maximise the fall of the chain. If the chain falls alongside a bulkhead or onto the stem it will pyramid and be more likely to jam.

If the windlass requires positioning such that chain falls into an undesirable position, a metal tube can be fitted under the hawser to redirect the chain to a more suitable position. This pipe should be at least 2 times the diameter of the chain. It should also be as vertical as possible. Position the windlass in the best location with the chain hawser facing forward.

Ensure sufficient room to run electric cables to the windlass. Follow the installation instructions, including underdeck stiffening, deck camber, alignment, mounting blocks and sealing procedures. The gearbox and motor can be located in one of 8 positions.

ELECTRICAL

See Wiring Diagrams for wiring instructions.

Circuit breaker (must be fitted to ensure warranty)

If the windlass is overloaded or stalled the circuit breaker will automatically cut power to the windlass and protect the wiring and motor. The circuit breaker should not be used as an isolating switch, purely for safety reasons.

Deck Switches are best located out to either port or starboard or directly behind the windlass in a position where it can be easily reached with your foot or knee, preferably where you can view the anchor and chain coming aboard.

Isolating Switch should be fitted in an accessible position for safety, ideally close to the battery or switches. The isolating switch is not a circuit breaker.

Batteries are best located as close to the windlass as possible. Larger cables will reduce the voltage drop to the motor and the heat generated when running the windlass. Small diameter cables drop voltage considerably. Use the following table as a guide to your required wire size:

Distance from battery to motor (m)	Cable Size		Cable Diameter (mm)
	(mm ²)	AWG	
7 (23')	25	4	8 (5/16")
9 – 17 (30' – 55')	70	1/0	12 – 15 (7/16" – 19/32")

Rotation: Windlasses may be wired for single or dual direction, using single or dual deck switches for raising or lowering. Alternatively a remote control solenoid package with Toggle Switch, Hand Pendant or Auto Anchor is available. Contact your Muir Retailer for further details

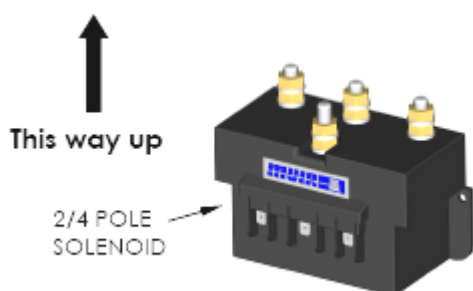

Solenoid Installation

We recommend that the solenoid is installed in an upright position, where it has minimal exposure to sea water and is in close proximity to the electric motor of the windlass.

For wiring information, please refer to the included wiring diagram.

WIRING LAYOUT

REMOTE SWITCH LAYOUT

- 1. BATTERY
- 2. CIRCUIT BREAKER
- 3. SOLENOID/CONTROL BOX
- 4. REMOTE SWITCH

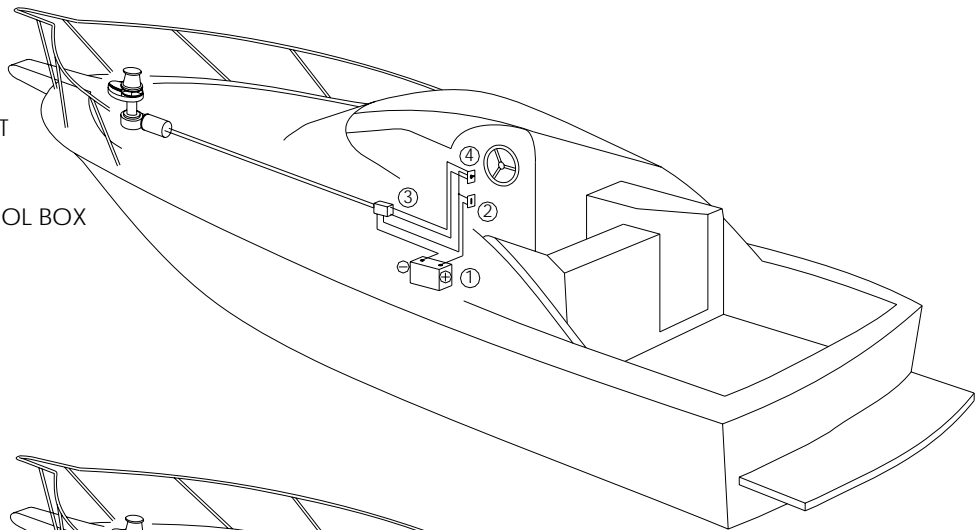

REMOTE / DECK SWITCH LAYOUT

- 1. BATTERY
- 2. CIRCUIT BREAKER
- 3. SOLENOID/CONTROL BOX
- 4. DECK SWITCHES
- 5. REMOTE SWITCH

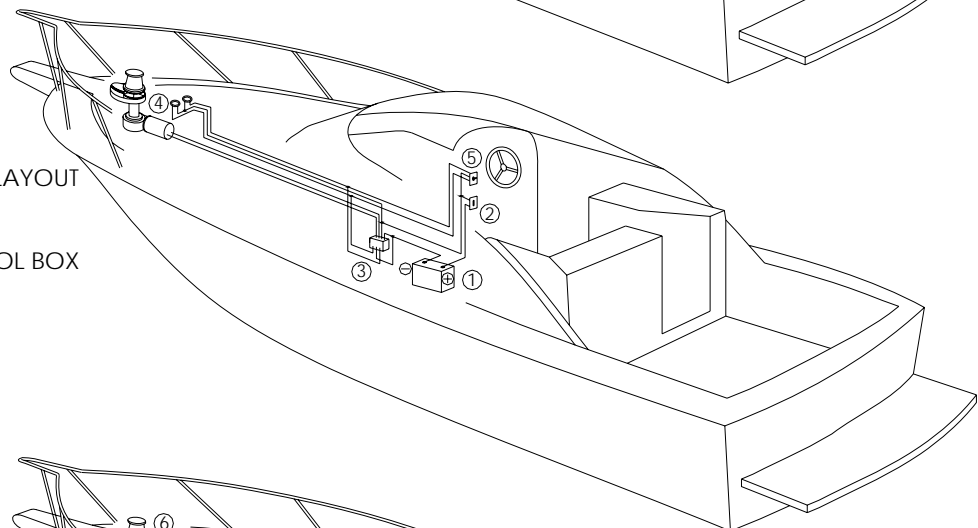

AUTO ANCHOR LAYOUT

- 1. BATTERY
- 2. CIRCUIT BREAKER
- 3. SOLENOID/CONTROL BOX
- 4. DECK SWITCHES
- 5. AUTO ANCHOR
- 6. AUTO ANCHOR SENSOR

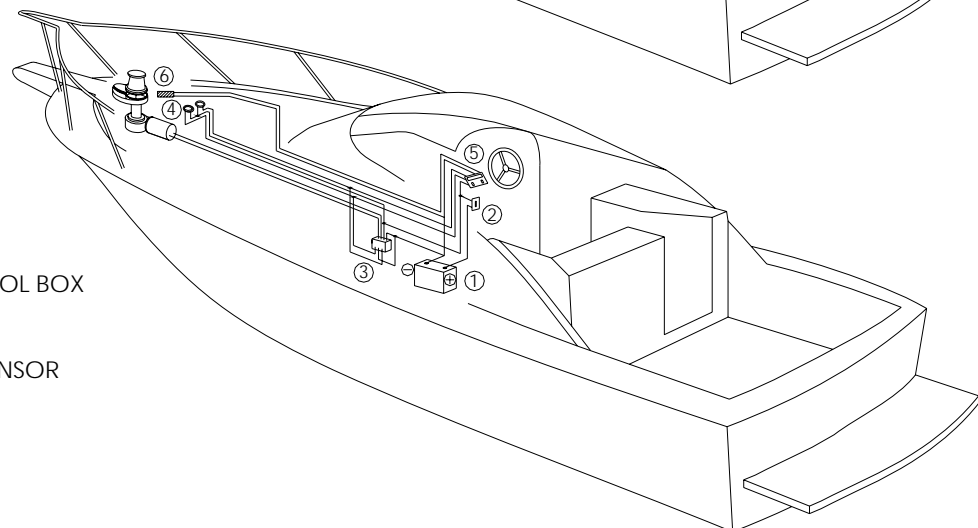

NOT TO BE USED AS WIRING DIAGRAMS

OPERATING INSTRUCTIONS – VR600 and VRC600

Manually releasing chain: To release the anchor rode, place the clutch handle into the clutch drive Bi-square as shown in the diagram at the bottom of the page and turn **anti-clockwise** to release the clutch brake. Let the anchor fall and control the run of the chain by tightening the clutch handle **clockwise** using the clutch mechanism as a brake.

Anchoring: When laying at anchor use a chain stopper, nylon/chain bridle or snubber line to prevent snatching and direct loading on the windlass main shaft. Never use the windlass as a mooring bollard.

Retrieving chain: Before operating the windlass tighten the clutch with the clutch handle in a **clockwise** direction, then remove the clutch handle. If the anchor is buried hard, motor forward to pull it free after hardening up on the windlass. This will ease the load on the windlass.

Rope hauling on the capstan: The capstan can be operated independently of the gypsy. Secure the anchor rode, (with a chainlock, gypsy lock or snubber), then release the clutch. The capstan may then be operated using the windlass motor.

Electric operation: Releasing and retrieving the anchor rode is identical when operating an electric windlass. Always keep well clear of the windlass when releasing or retrieving chain and anchor. Keep fingers, hair and clothing well clear when the windlass is in operation.

Auto Anchor Launching: If the anchor roller can be positioned so that the anchor falls as soon as the windlass is reversed, the whole operation can then be carried out remotely. Remote switching controls are self centering and stop the windlass when the switch is released. Mark the anchor end of the chain at 2 and 5 metre (6.5' & 16.5') intervals to enable the operator to judge when the anchor is almost up. Go slowly for the last few metres of retrieval by letting go of the switch, rather than waiting for the anchor to fly up over the roller and bang tight, as this practice puts excessive load onto the bow roller, windlass and foredeck, so should be avoided.

SERVICING

Rinsing all deck gear with fresh water after every excursion ensures that salt deposits and corrosion are kept to a minimum. We recommend that windlasses affixed to pleasure craft are stripped yearly and all moving parts cleaned and greased with a grease suitable for marine applications, (such as Duckhams Keenol or Castrol LMX). In the case of workboats and charter vessels we suggest that this maintenance is carried out more frequently. **Do not use soap based grease.**

Atlantic models have a grease nipple on the aft side of the base plate which lubricates the main drive shaft. The geardrive is filled and sealed at factory with long life synthetic oil that does not require replacement for the life of the geardrive.

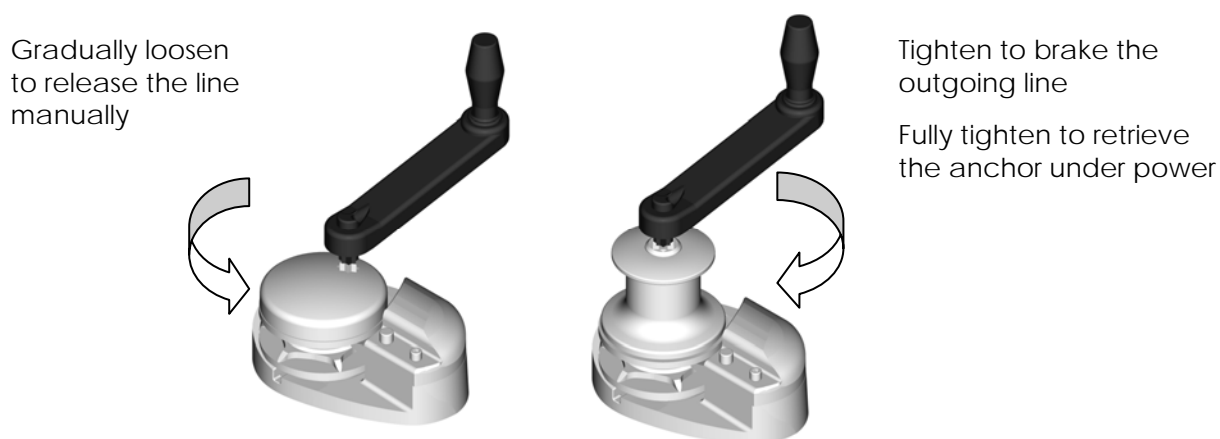

MAINTENANCE AND ASSEMBLY INSTRUCTIONS – VR600 and VRC600

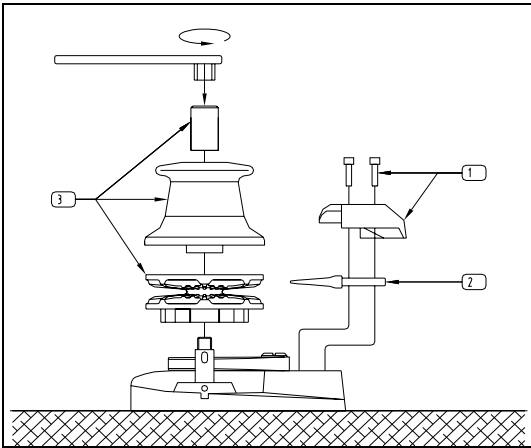

Standard VRC600

For this you require the clutch handle, 3mm and 6mm allen keys and a marine grade grease.

1. Remove two screws and chain cover.
2. Remove peeler.
3. Fully unscrew clutch nut and remove capstan. Remove key from shaft. Hold the peeler arm out and remove gypsy.
4. Repeat steps 1-3 in reverse order. Lubricate shaft, gypsy, drive cone and capstan.

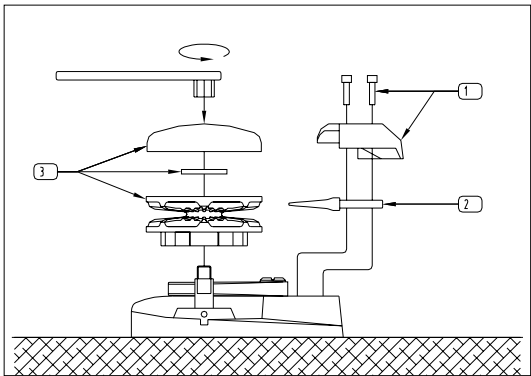

Standard VR600

For this you require the clutch handle, 3mm and 6mm allen keys and a marine grade grease.

1. Remove two screws and chain cover.
2. Remove peeler.
3. Fully unscrew clutch nut and remove D washer. Hold the peeler arm out and remove gypsy.
4. Repeat steps 1-3 in reverse order. Lubricate shaft, gypsy and drive cone.

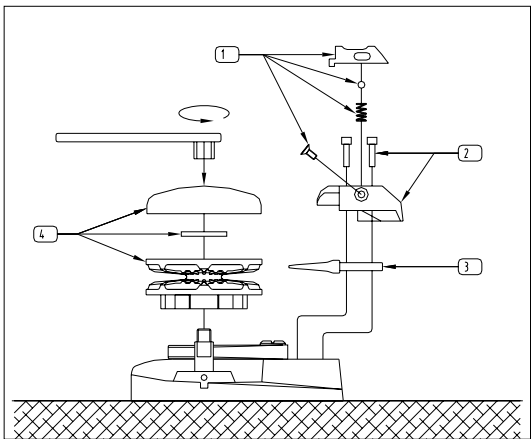

VR600 With Locking Pawl

For this you require the clutch handle, 3mm and 6mm allen keys, a small screwdriver and a marine grade grease.

1. Remove screw on side of chain cover. Carefully remove locking pawl, spring and ball bearing. (Spring and ball bearing may be stuck to the bottom of the locking pawl).
2. Remove two screws and chain cover.
3. Remove peeler.
4. Fully unscrew clutch nut and remove D washer. Hold the peeler arm out and remove gypsy.
5. Repeat steps 1-4 in reverse order. Lubricate shaft, gypsy and drive cone.

- The Windlass Base Plate can be greased via the grease nipple located at the rear of the base.
- The Motor/geardrive assembly should be protected with anti-corrosion film or grease tape.

OPERATING INSTRUCTIONS: VFF600

The concept of the freefall windlass is to deploy and freefall an anchor remotely from the helm station.

1. Engaging the down switch or reversing the windlass automatically releases the clutch allowing the chain gypsy to free wheel thus dropping the anchor.
2. Engaging the up switch of the windlass will automatically tighten the clutch allowing the winch to take up any slack in the anchor rode. **This must be done only when the anchor and all of the rode has touched the bottom and not whilst in freefall.**
3. Release the switch when sufficient slack in the anchor rode has been taken up.
4. To retrieve the anchor, operate the windlass in the up direction. It is also recommended that the vessel is motored into the wind/towards the anchor to minimise excessive load on the windlass.
5. If necessary the windlass can be powered down without freefall. This is done by releasing the grub screw and rotating the striker pawl 180 degrees. (*See Maintenance and Servicing 3a, Page 12*).
6. The clutch can also be operated manually using the above method. The clutch **has a left hand thread**, so to release the clutch turn the handle in a clockwise direction and to tighten turn the handle in an **anticlockwise direction**.
7. For the efficient operation of the windlass periodically **apply grease to the striker pawl** located on top of the chain pipe cover.
8. The Rope Chain Management System nylon fingerapplies pressure to the line and splice and must be tightly tensioned onto the gypsy without line fitted by releasing the grub screw and adjusting the finger pin by tightening anticlockwise.

IMPORTANT:

IT IS NECESSARY TO INSTALL AN ISOLATION SWITCH AS WELL AS A CIRCUIT BREAKER TO THE FREEFALL WINDLASSES TO ISOLATE THE WINDLASS WHEN NOT IN USE. This is to prevent the rope and chain from paying out if the winch is accidentally reversed.

MAINTENANCE AND SERVICING

VFF 600 Free Fall Windlass

1. Tools required

- (i) Muir clutch handle (P/N. F90-HANNYL0600)
- (ii) Phillips Head screw driver
- (iii) Flat blade screw driver
- (iv) 6mm (1/4") Allen key
- (v) 3mm (1/8") Allen key
- (vi) 3/16" Pin punch
- (vii) VFF 600 exploded view Dwg. K08-FREVFF0600

2. **Removing clutch nut retaining washer** (P/N. P21-304020.0007.005) & screw (P/N. S33-30406.00012). Place Flat blade screwdriver (A) into slot screw and then turn anti-clock wise to remove.

- 3a. **Removing declutching pawl** (P/N. P13-PWL303VFF600A). Place 3mm (1/8") Allen key (B) into grub screw and then turn anti-clock wise to release.

- 3b. **Removing 3/16" roll pin** (S93-PIN04.76025). Place 4mm (3/16") pin punch into point (C) and then tap carefully with a hammer to remove.

4. **Removing chain cover** (P/N. P05-CCVBR0600FF). Place 6mm (1/4") Allen key into (D) & (E) socket head cap screw (P/N. S45-30406.35025) and then turn anti-clock wise to remove. Now the chain cover can be removed.

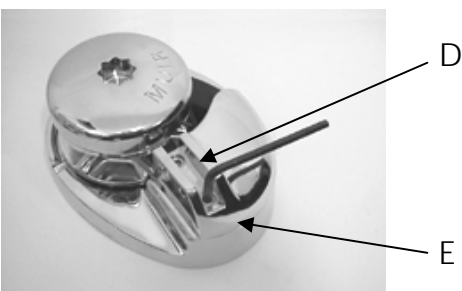
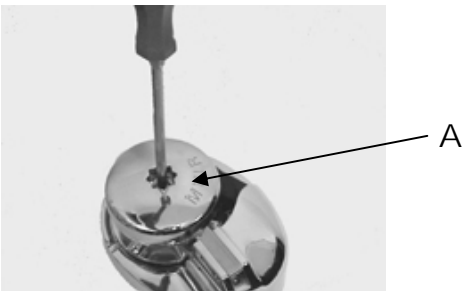

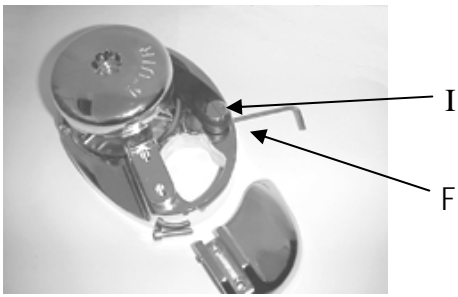

5. **Removing PVC finger** (P/N. R40-FGRPVC0600A). Place 3mm (1/8") allen key into (F) grub screw (P/N. S35-30406.35BSW006) and then turn anti-clock wise to remove. The finger can now be removed.

Re-assembly: Tensioning the finger: Place flat bladed screwdriver into (I) slot of Pin, then turn anti-clock wise ¼ turn & hold. Then tighten (F) Grub screw.

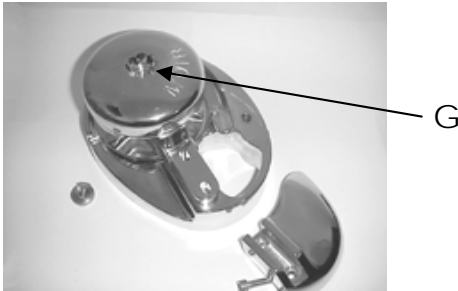

6. **Removing clutch cap** (P/N. P07-CLNBRZVFF600A1). Place Muir clutch handle into bi-square (G) and then turn **clockwise** (left hand thread) to remove.

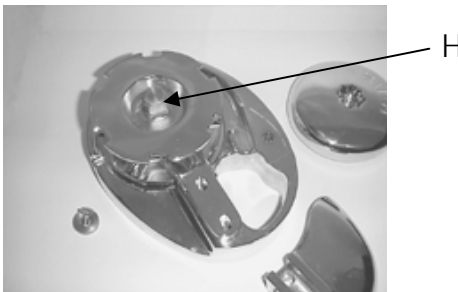

7. **Removing gypsy** (P/N. P10-A0600), peeler (P/N. P05-PLRBRZ0600) & stripper (P/N. P19-STR3040600A). These parts can now be slid off the main shaft (H).

Re-assembly: When placing gypsy back on the shaft make sure that the notches are on top.

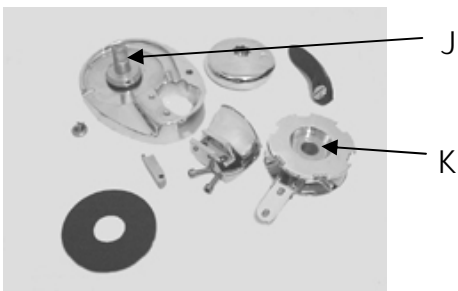

- Before re-assembly, grease the exposed main shaft/cone (J) & gypsy bore (K).
- The windlass base plate (P22-BSEBRZ00600A) can be greased via the grease nipple located (L) at the rear of the base.
- The Motor/geardrive assembly should be protected with anti-corrosion film or grease tape.

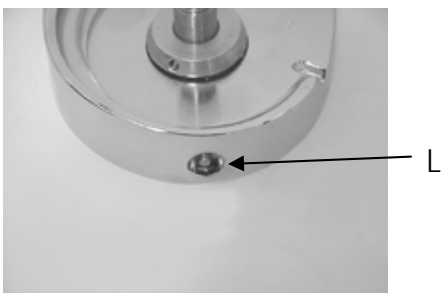

ROPE CHAIN MANAGEMENT SYSTEM (RCMS) ADJUSTMENT

Firm tension of the finger is required to reduce rope (nylon line) slipping through gypsy. To adjust this tension (if line slippage is experienced) refer to the procedure below:

PROCEDURE:

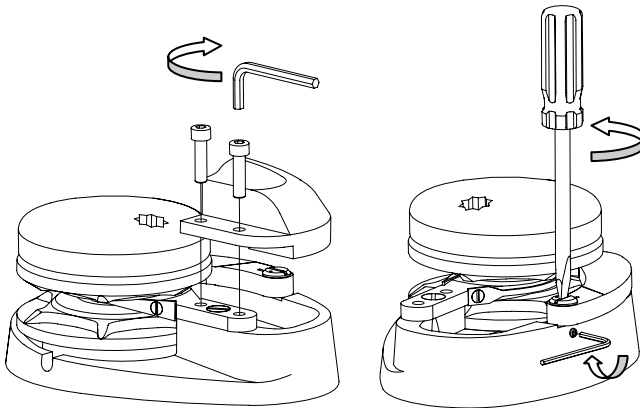

Tools Required: Allen keys and a large flat screwdriver.

1. Undo the two socket head screws with an allen key to remove the chain cover.
2. Loosen the grub screw on the side of base with an allen key for finger adjustment.
3. Turn screwdriver **anti-clockwise** to tension the spring. While holding the tension, re-tighten grub screw.
4. Reattach the chain cover to finish the adjustment.

Line Care

Using the wrong type of line may cause the line to jam or slip, causing excessive line wear. Muir Windlasses are designed to run on 3-strand nylon line (supplied by Muir) which has been specially treated with fabric softener to prevent it from hardening. It is recommended to soak your rope in fresh water containing fabric softener every 3 months.

In case of a rope jam, slacken off the windlass clutch to free the jammed line. When retrieving the anchor rode do not continue to run the windlass if the anchor or chain is jammed, as line slippage in the gypsy will cause damage to the line.

Rope/Chain Splice.

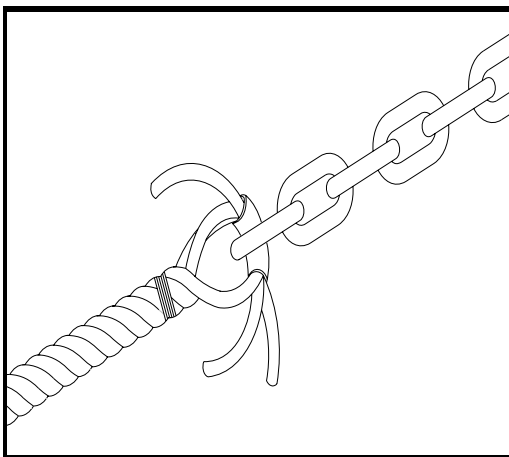

1. To stop rope unravelling, seize rope 400mm(16") from end with whipping twine. Unlay strands.
2. After placing 20mm (3/4") of heat shrink sleeve tubing through the last link of chain, pass one strand of rope through sleeve and chain from one side and the other two strands of rope from the opposite side. (See illustration).
3. While pulling all three strands tight, shrink the sleeve tightly onto the rope using a hairdryer or fan heater or by immersing in boiling water.
4. Remove seizing and complete back splice in normal manner for two full tucks. With a hot knife pare down the three strands by 1/3 and insert two further tucks. Pare down by another 1/3 and finish with two tucks. Cut any remaining tails.

TROUBLESHOOTING

ELECTRICAL

1. Check the battery circuit breaker and ensure the isolating switch is on.
2. Check battery is charged up to 12 or 24 volts (as relevant).
3. Check that the foot switch plunger is contacting.
4. Check remote control solenoid is contacting. If this is clicking, the problem may be low voltage, a faulty solenoid or a wire not properly connected.
5. Check wiring between controls, solenoid and motor are intact.
6. If the motor will not turn after checking the above points, check that the motor bushes are not worn or sticking.

MECHANICAL

1. Check that the clutch above the chain gypsy is tightened to the chain gypsy drive using the manual handle supplied (refer to operating instructions section of this manual).
2. If the line slips check the tension on the finger and increase spring tension (refer to RCMS adjustment section of this manual).
3. Check the drive key on main shaft to gearbox output.
4. Check the drive key between the gearbox and motor input.

WATER PROTECTION DIAGRAM

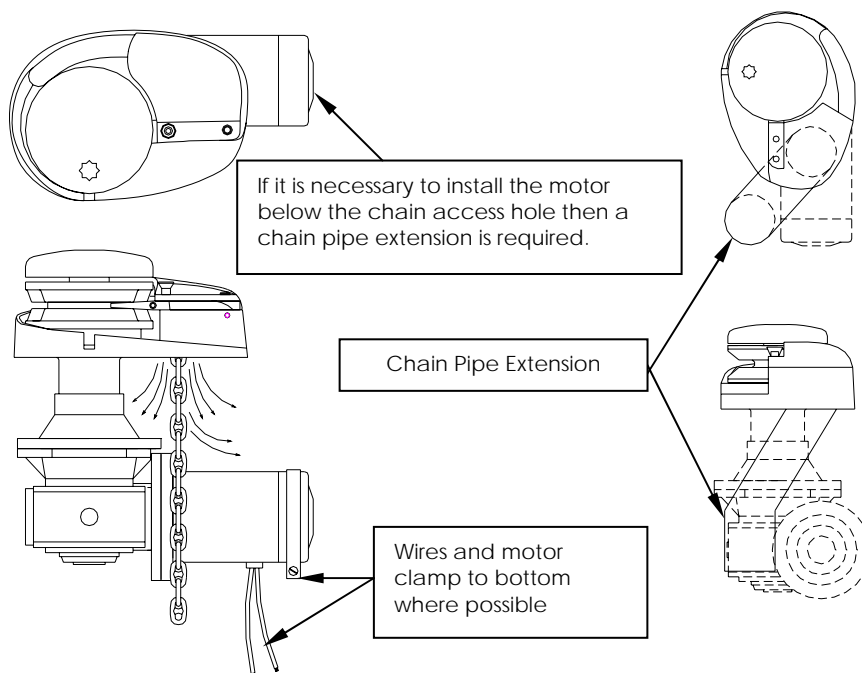

NOTE:

It is important to thoroughly lubricate all mating surfaces with grease suitable for marine applications.

Corrosion protection should be applied to the external surfaces of the motor, gearbox and adaptor and also in any areas that water may lie.

Recommended products for anti corrosion protection are Techtyl under body anti corrosion film and Denso grease tape.

THIS PAGE INTENTIONALLY LEFT BLANK

Warranty Limited for period of Three years (First Owner)

We warrant each new product manufactured by us to be free from defects in material and workmanship for a period of 3 years (first Owner).

This warranty shall become effective only upon receipt of a completed warranty registration, which shall identify the product so registered by serial number. This warranty shall remain in effect for a period of three (3) years from the date of purchase. For vessels in charter or hire the warranty is one (1) year due to various operators and overloading which may occur.

Conditions

While this warranty applies to defects in material and workmanship, it does not apply to:

- Normal worn parts or to damage caused by neglect, lack of maintenance, accident or improper service/installation or service by persons other than an authorised Muir representative.
- Muir shall not be responsible for failures due to products being used in applications that they are not intended for, or exceed the products performance specifications.
- For warranty claim, defective product must be returned to Muir for inspection.
- Muir will not be responsible for freight charges, removal or installation labour on warranty claims.
- Damage due to unsatisfactory storage or use of equipment prior to installation in the approved/intended manner.

Exclusions

Warranty is limited to twelve months for:

- Electric motors / controls / equipment
- Hydraulic pumps / controls / valves
- Weather seals
- Use on charter/hire/commercial boats

All incidental and/or consequential damages are excluded from this warranty. Warranties of merchantability and fitness are excluded from this warranty. Implied warranties are limited to the life of this warranty. Some countries do not allow limitations on how long an implied warranty lasts or the exclusion or limitation of incidental or consequential damages, so the above may not apply to you.

We reserve the right to improve the design or materials used on any product without assuming any obligation to modify any product previously manufactured or used.

Liability

Muir Engineering liability under this warranty shall be to the exclusion of all other warranties or liabilities (to the extent permitted bylaw). In particular (but without limitation):

Muir Engineering shall not be liable for:

Any indirect or consequential loss including (without limitation) any loss of anticipated profits, damage to reputation or goodwill, loss of expected future business, damages, costs or expenses payable to any third party or any other indirect losses. Any damage to yachts or equipment. Death or personal Injury (unless caused by Muir Engineering negligence).



WARRANTY REGISTRATION CARD

Return To

MUIR ENGINEERING PTY. LTD.
100 Browns Rd, Kingston
Tasmania, Australia, 7050

**WARRANTY VOID UNLESS CIRCUIT
BREAKER OR RELIEF VALVE FITTED**

Customer / Company Name:
Contact (if Company):
Address:
Phone / Email:

Winch Model:
Serial Number:
Purchase Date: <div style="text-align: center; font-size: 1.2em; margin-top: 5px;">dd / mm / yyyy</div>
Purchased From:
Invoice Number / Receipt Number / Proof of Purchase:

THIS PAGE INTENTIONALLY LEFT BLANK

THIS PAGE INTENTIONALLY LEFT BLANK



Head Office:

100 Browns Road,
Kingston Tasmania,
Australia 7050
Tel Int: +61 (0) 3 6211 8811
Fax Int: +61 (0) 3 6229 7030
Email: info@muir.com.au
www.muir.com.au

WINDLASS
SERIAL NUMBER

© 2005 Muir Engineering Pty. Ltd. Muir reserves the right to alter specifications without notice. All rights reserved.

While all due care and attention has been taken in the preparation of this manual no responsibility shall be taken for errors or omissions.